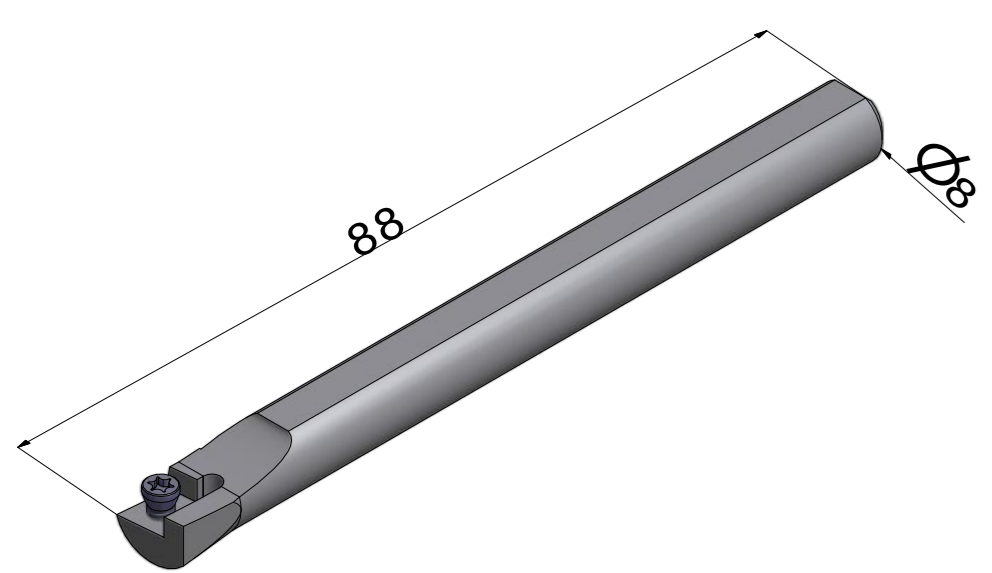
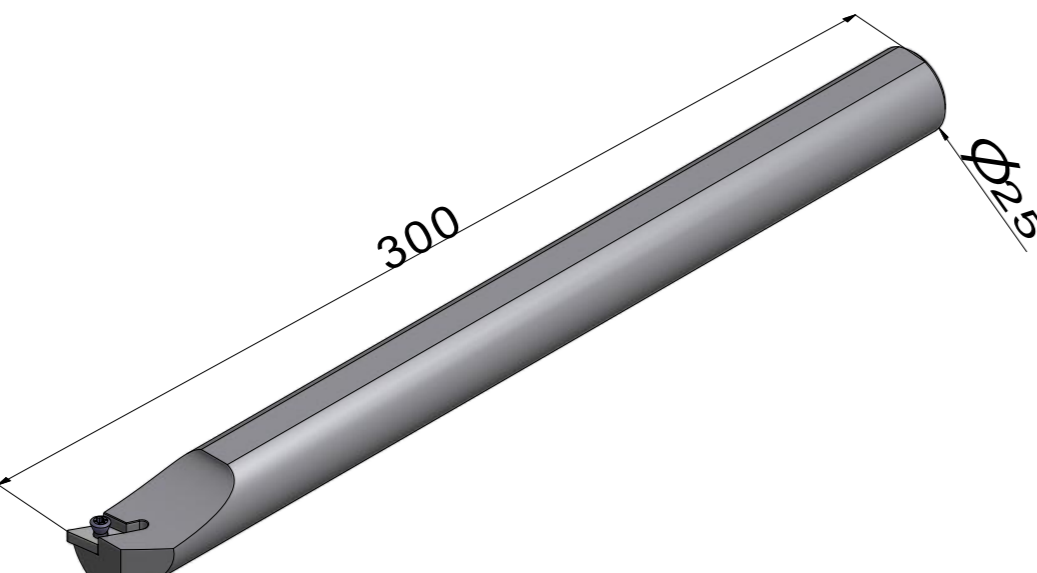
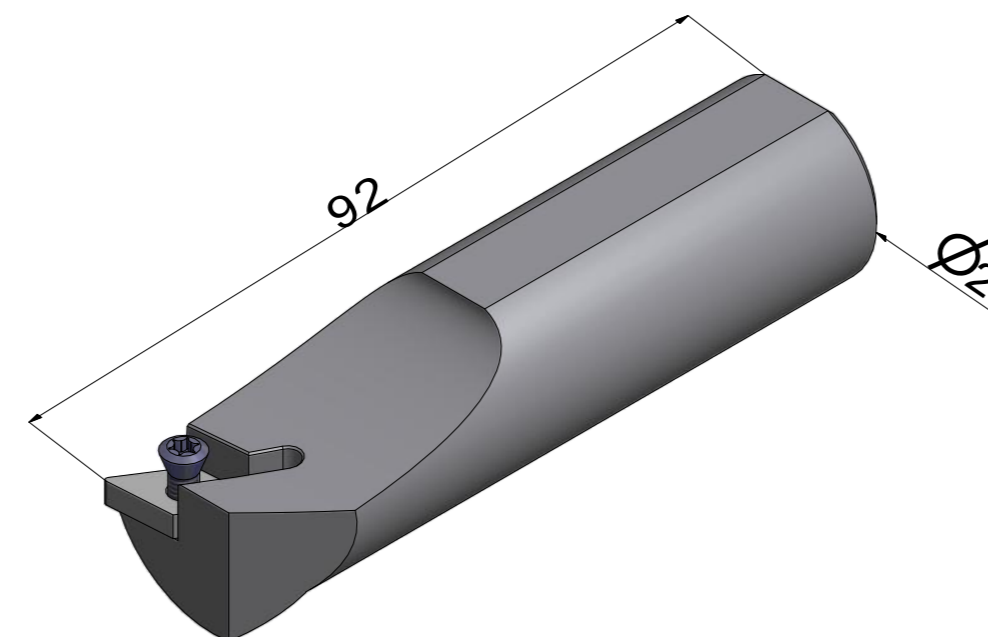
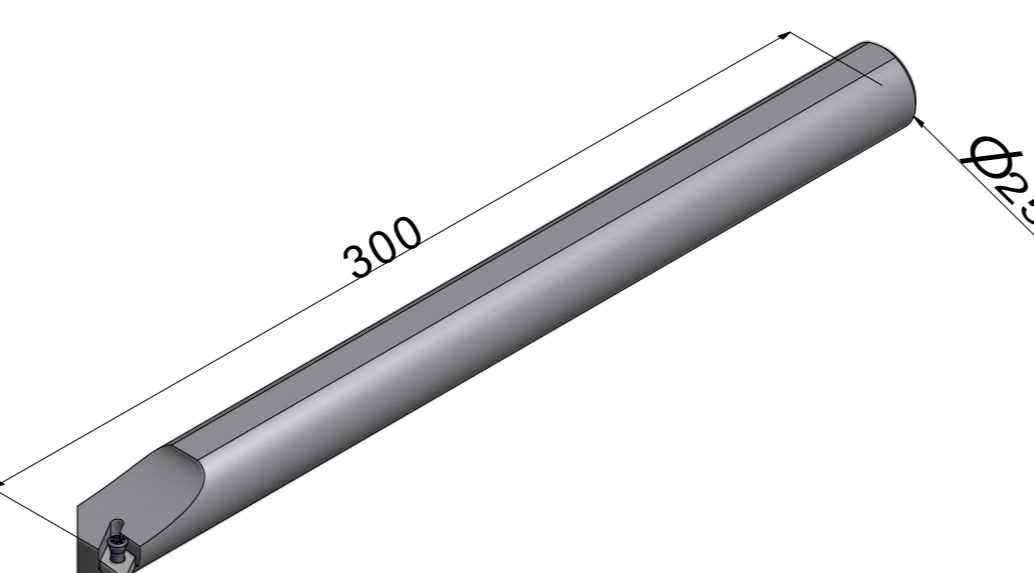
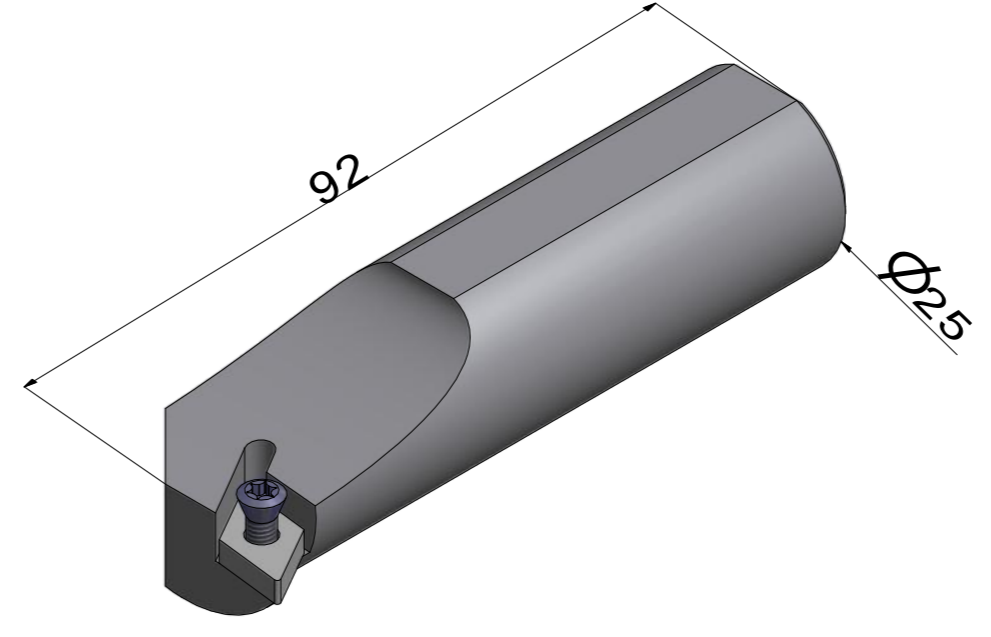
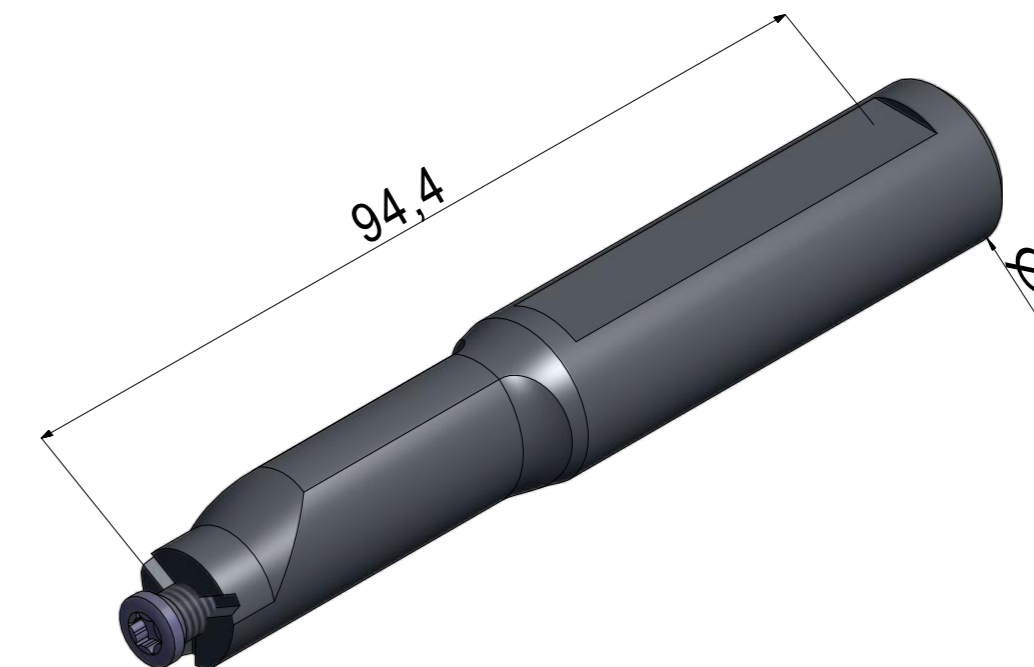
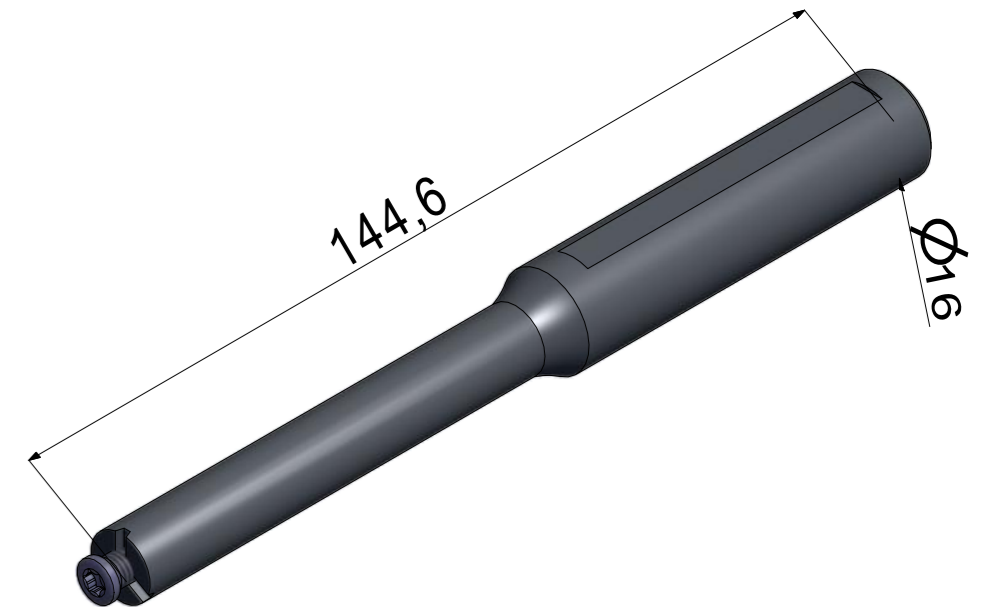
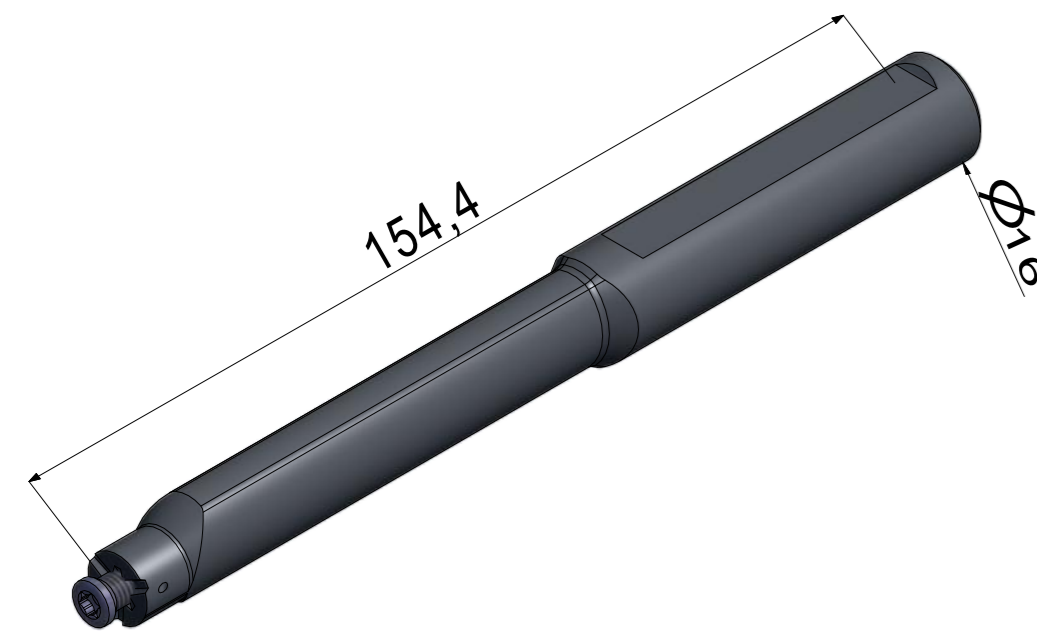
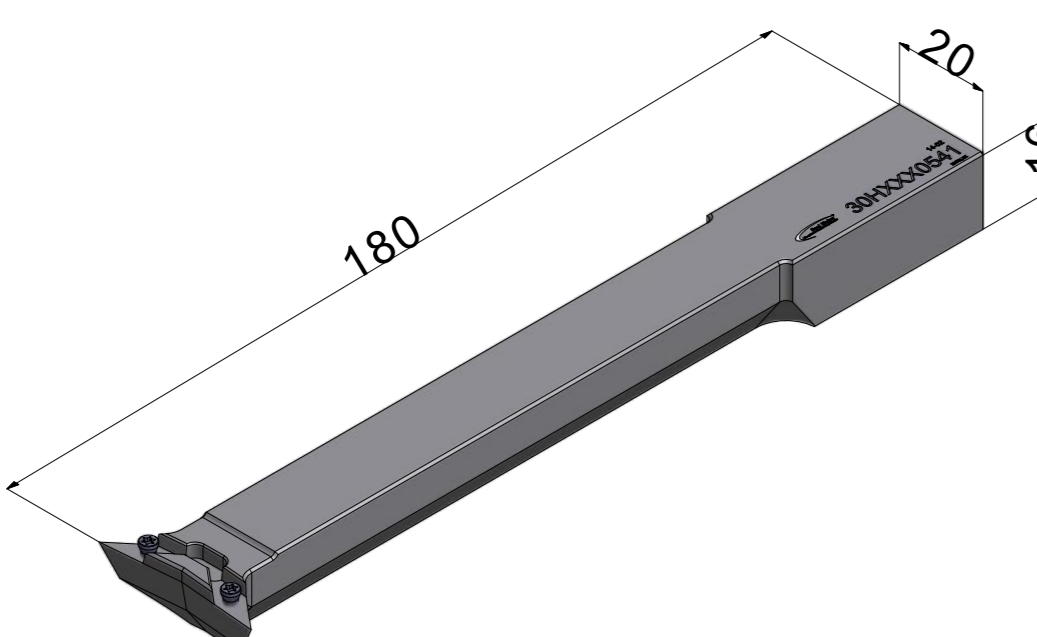
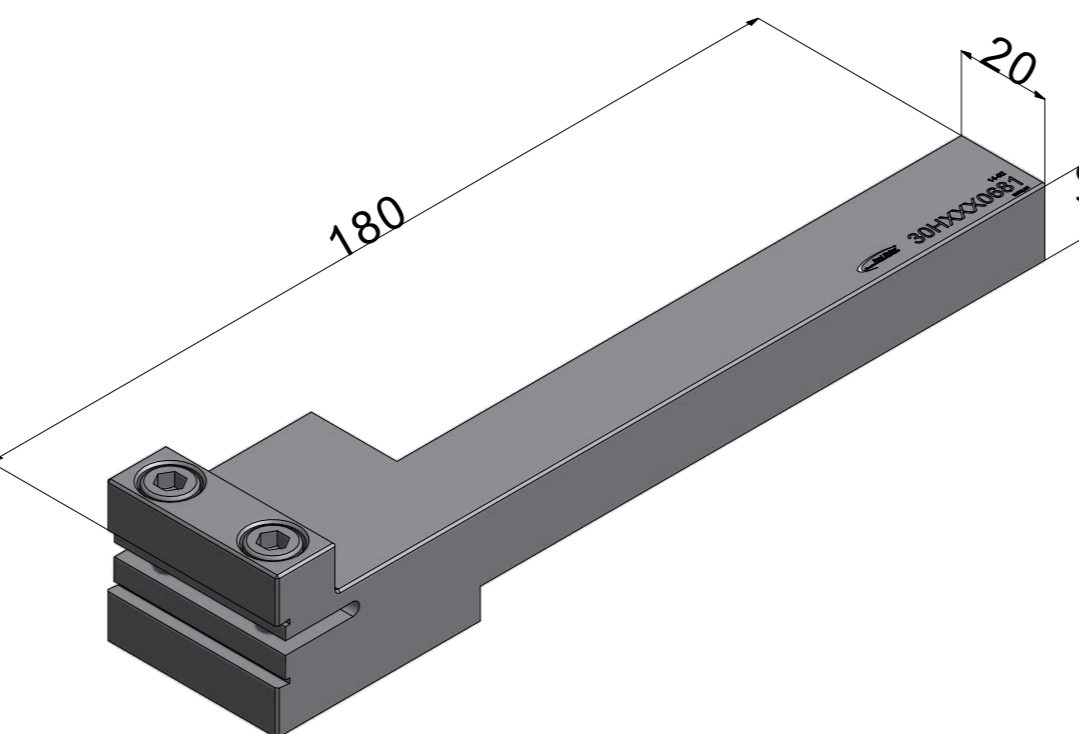
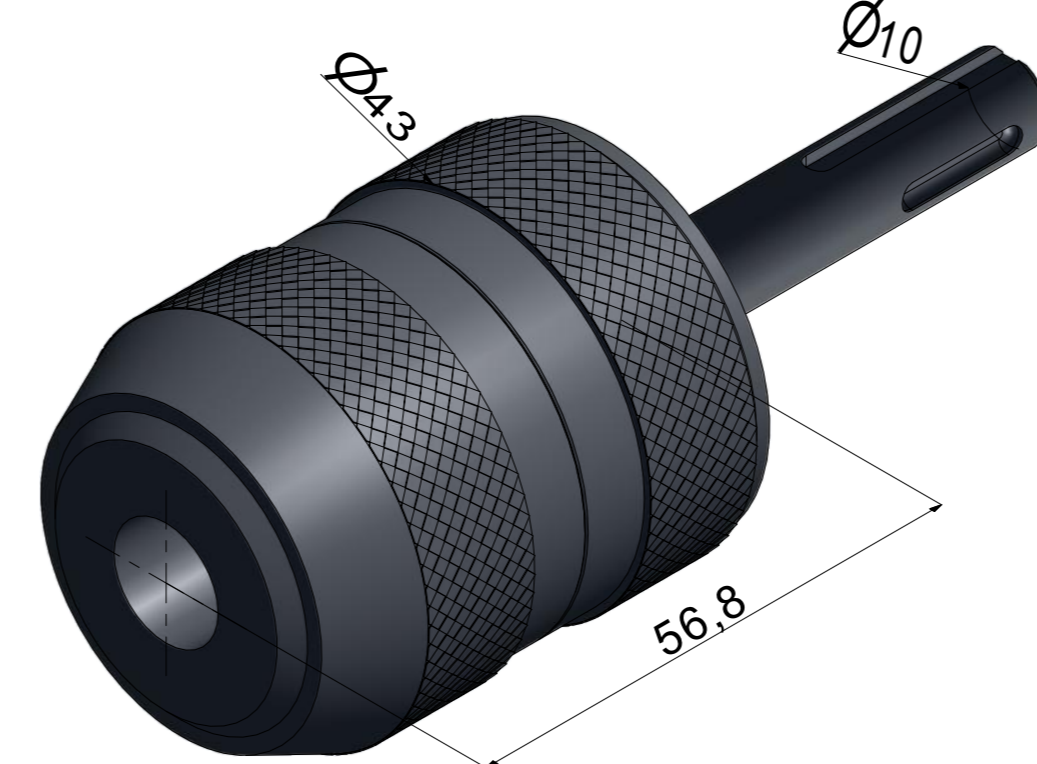
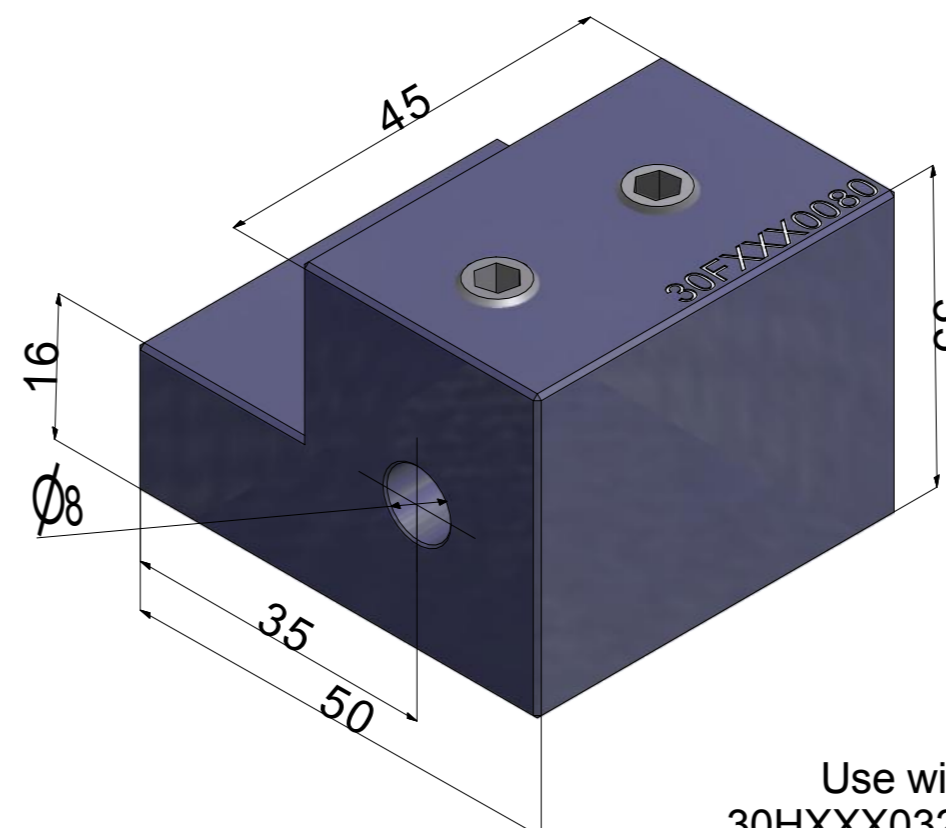
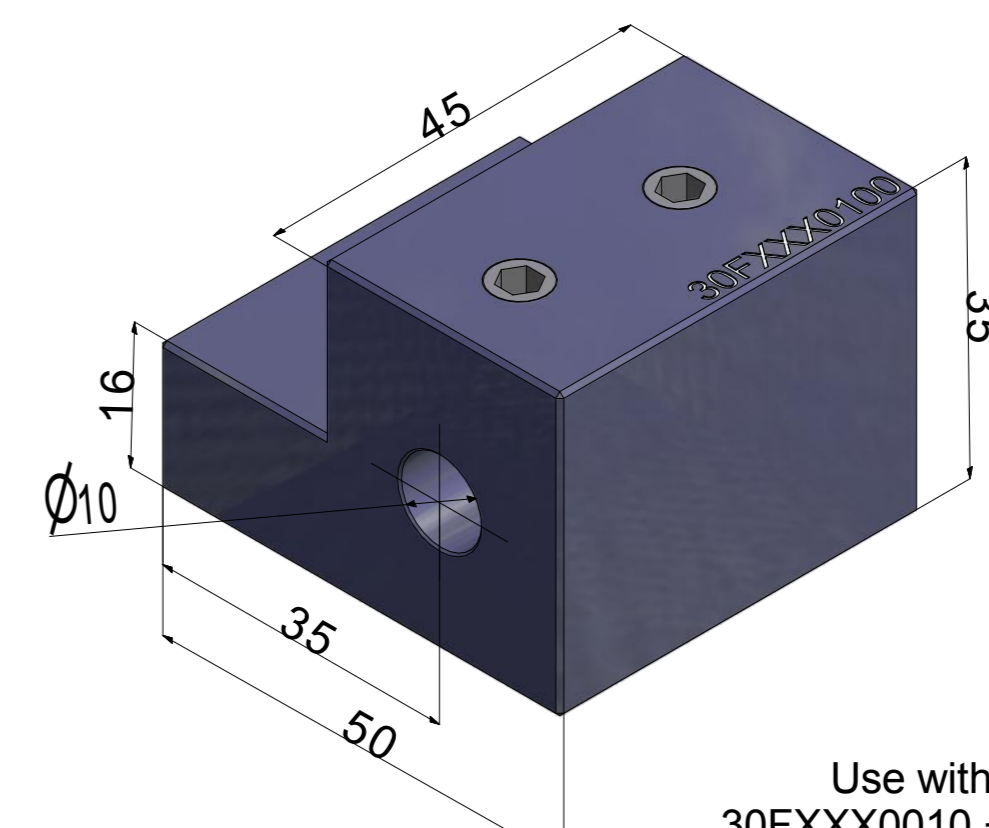
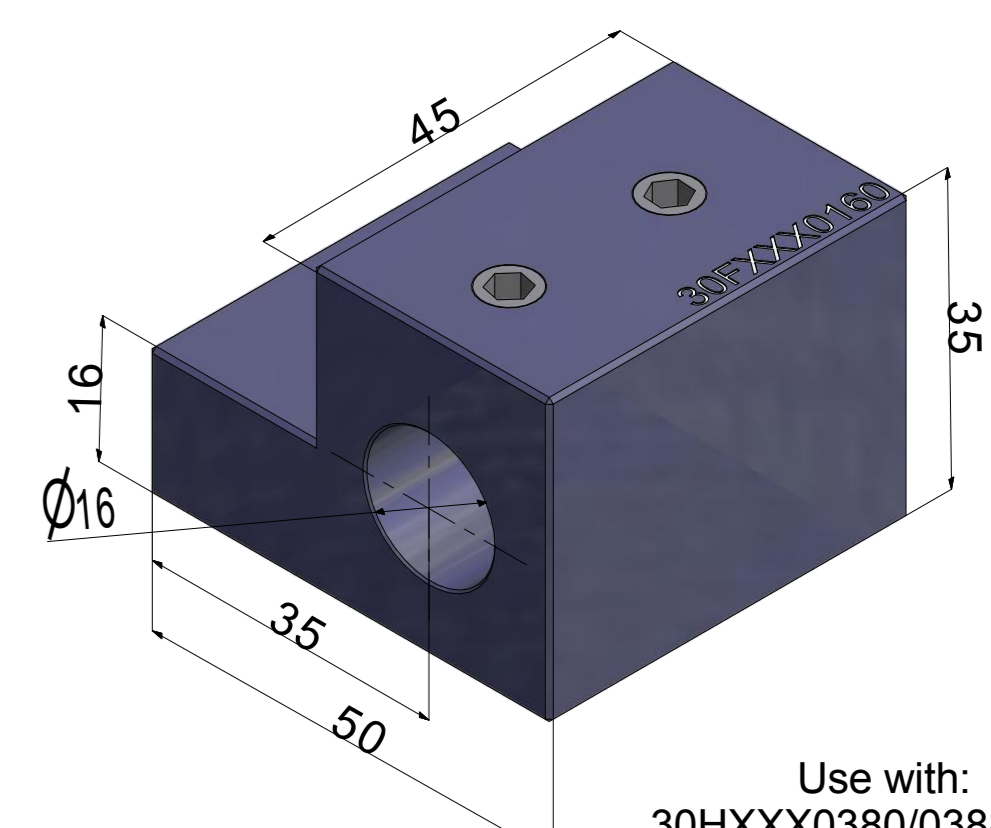

Tool holder overview for horizontal SML-machines part 2 (SML500e / SML170 - 700)

<p>30HXXX0330</p>  <p>Use with Inserts: 30IXXX0950/0955</p>	<p>30HXXX0340</p>  <p>Use with Inserts: 30IXXX0960/0960B</p>	<p>30HXXX0350</p>  <p>Use with Inserts: 30IXXX0960/0960B</p>	<p>30HXXX0360</p>  <p>Use with Inserts: 30IXXX0960/0960B</p>	<p>30HXXX0370</p>  <p>Use with Inserts: 30IXXX0960/0960B</p>	<p>30HXXX0380</p>  <p>Use with Inserts: 30IXXX0287/0288/0350 0352/0354/0356/0358/0360/0370 0372/0374/0376/0378/0380/0390</p>	<p>30HXXX0388</p>  <p>Use with Inserts: 30IXXX0400/0410</p>
<p>30HXXX0390</p>  <p>Use with Inserts: 30IXXX0287/0288/0350 0352/0354/0356/0358/0360/0370 0372/0374/0376/0378/0380/0390</p>	<p>30HXXX0541</p>  <p>Use with Inserts: 30IXXX0010A/0010B 0020A/0020B/0025A</p>	<p>30HXXX0681</p>  <p>Use with Inserts: 30IXXX0300/0300A/0310</p>	<p>30FXXX0010 + 0011</p>  <p>Use with: milling tools and drills with shaft ø 1mm - 13mm</p>	<p>30FXXX0080</p>  <p>Use with: 30HXXX0320/0330 milling tools and drills with shaft ø 8mm</p>	<p>30FXXX0100</p>  <p>Use with: 30FXXX0010 + 0011 milling tools and drills with shaft ø 10mm</p>	<p>30FXXX0160</p>  <p>Use with: 30HXXX0380/0388/0390 milling tools and drills with shaft ø 16mm</p>